

How to cite / Как сослаться на статью:

**A Lebedev et al 2020 IOP Conf. Ser.: Mater. Sci. Eng.
1001 012005. doi:10.1088/1757-899X/1001/1/012005**

Unsteady processes in a centrifugal compressor: from a physical experiment to a virtual stand

Lebedev A.A.¹, Kozhukhov Y.V.¹, Ivanov V.M.¹, Kartashov S.V.¹, Nguyen M.H.², Lebedeva S.M.¹, Lopulalan Kh. D.¹, Aksenov A. A.¹

¹ Peter the Great St. Petersburg Polytechnic University Federal State Autonomous Educational Institution of Higher Education, St. Petersburg, Russia.

² PetroVietnam Exploration Production Corporation Ho Chi Minh City, Viet Nam

Abstract. Virtual testing unit description for unsteady flow phenomena investigations in a centrifugal compressor based on ANSYS 12.0 system is presented. Comparisons of calculated and experimental results for steady and unsteady data are acceptable. Transient Blade Row methods (the CFX Transient Blade Row Modeling with the terminology of Turbo component) - is the sector of blades in a given blade row that are being modeled in the analysis. Transient Rotor-stator analyses involve at least two components, one rotating and one stationary component

Keywords: unsteady processes, virtual stand, centrifugal compressor, ansys, rotating breakaway, aerodynamic, three-dimensional model.

1 Introduction

Unsteady processes play the main role in the formation of an increased level of dynamic stresses in the compressor units, its vibrations and aerodynamic noise. Compressor design is performed without taking into account the possibility of occurrence of unintended aerodynamic processes such as rotating breakaway and aerodynamic resonance or intense chaotic pulsations within the operating range of the characteristic, which often leads to accidents. Experimental study of aerodynamic unsteady processes on the model and full-scale units is a complicated procedure that requires not only specially equipped stands with modern measuring and recording equipment (low-inertia pressure sensors, hot-wire anemometers, laser anemometers, etc.), but also highly qualified experimenters.

2 Methods

MORE ABOUT COMPRESSOR TECHNOLOGY AT WWW.KVIHT.COM
БОЛЬШЕ О КОМПРЕССОРНОЙ ТЕХНИКЕ НА WWW.KVIHT.RU

The rapid growth of modern computing technology makes it possible to set the task of creating a virtual stand for the study of unsteady processes in the flow path of a centrifugal compressor. It is necessary to have detailed data on the geometry of the research object, characteristics of measuring and recording equipment for pneumometric measurements and measurements of rapidly changing quantities, experimental and data processing reports for a such stand

3 Results

The experimental stand ETSK-1M of the Vacuum Compressor Technology and Pneumatic Systems department meets all requirements, which extensive research cycles of unsteady processes in typical stages of a centrifugal compressor [1-10], with measurements of rapidly changing processes both in impellers and in stationary elements (diffusers) using hot-wire anemometers and low-inertia pressure sensors, were performed on. Pneumometric measurements were carried out using traditional methods. The results were obtained over a wide range of operating characteristics, from maximum flow to surge boundary. The stand layout is shown in Fig. 1 [1, 11].

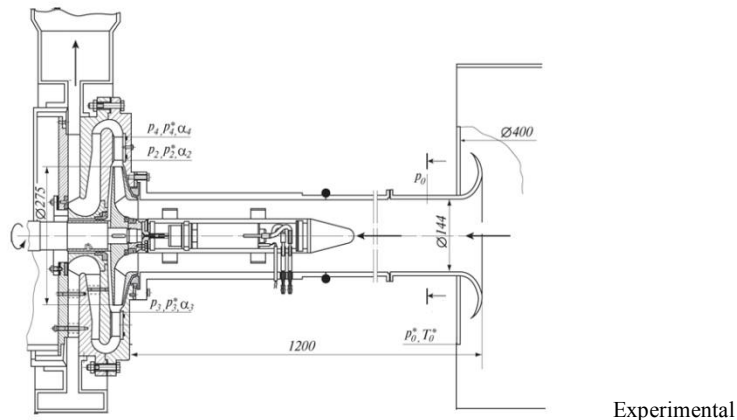

Fig. 1. stand ETSK-1M [1, 11].

Unsteady processes were investigated in an intermediate stage formed by a closed impeller ($\beta_{12} = 49^\circ$, $\beta_{11} = 34^\circ$, $z = 16$, $b_2 / D_2 = 0.0545$) and a bladeless diffuser with parallel walls ($b_3 / b_2 = 1.1$, $D_3 / D_2 = 1.048$, $D_4 / D_2 = 1.485$) in the experimental stand ETSK-1M. Low-inertia pressure sensors and hot-wire anemometers were used (Fig. 2) during the experiment. Information processing in real time was carried out using a specialized information-measuring system. The total time spent on the experiment and data presentation is about 2 years [11].

MORE ABOUT COMPRESSOR TECHNOLOGY AT WWW.KVIHT.COM
БОЛЬШЕ О КОМПРЕССОРНОЙ ТЕХНИКЕ НА WWW.KVIHT.RU

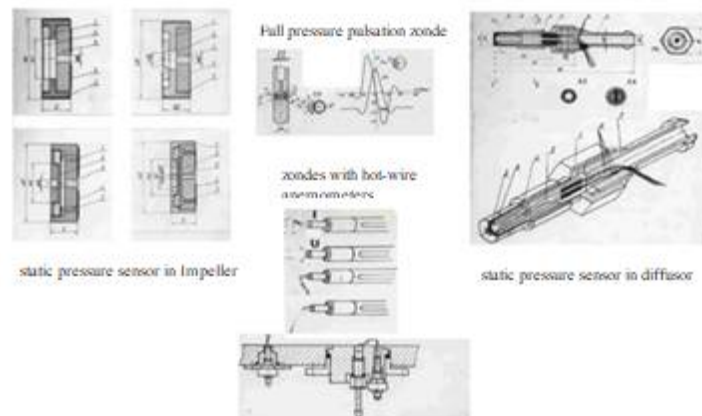

Fig. 2. Schemes of low-inertia static pressure sensors and hot-wire anemometers [1, 11].

The virtual stand (Fig. 3) consists of a rotating impeller (blue), an interface section (green) and a vaneless diffuser (red). Areas in end clearances and labyrinth seals are not considered.

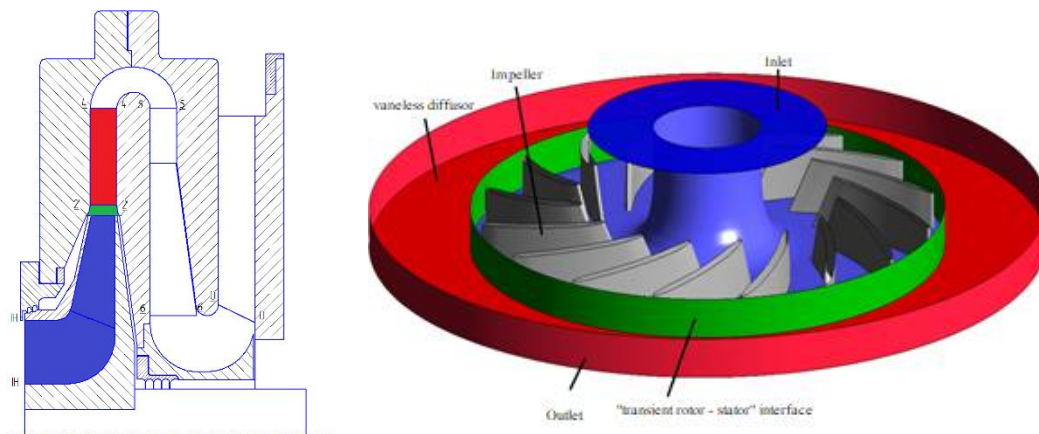

Fig. 3. Virtual stand ETSK-1MN (left) and three-dimensional model (right).

Unsteady processes were calculated using ANSYS CFX 12.0 in the cluster multiprocessor system of SPbPU. The unsteady Navier - Stokes equation was solved in the three-dimensional region over the entire coverage angle 2π . The output of the results (Fig. 4) was carried out at the same points at which the flow parameters were measured in the experiment [11].

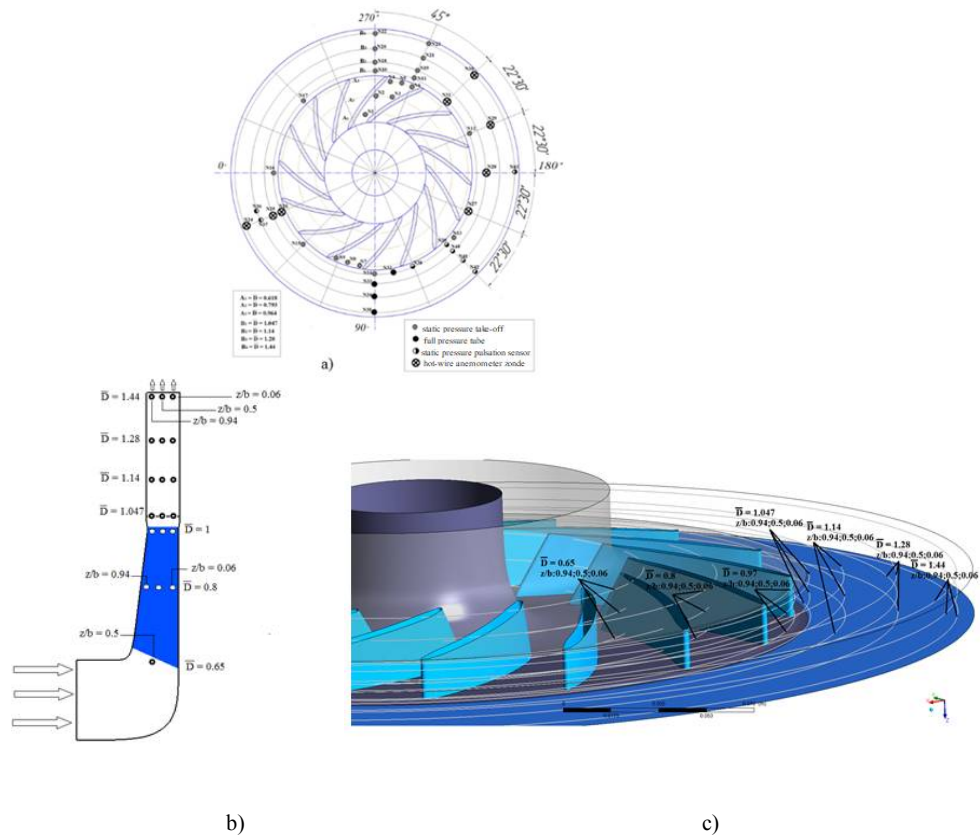

Fig. 4. Arrangement: (a) sensors in Impeller and vaneless diffuser [1,12, 13,14], (b) points and (c) calculation lines in ANSYS CFX Pre.

ANSYS Blade Modeler of ANSYS Workbench [15-19] was used to construct the geometry of the object. Computational grids were built with ANSYS Turbo Grid. The topology of the H/J/C/L grids was used for this geometry and O-Grid was used for the Impeller profiles with a width factor of 0.5. The number of cells in the area of the vane channel is 1 968 360 nodes. The total number of nodes is 31 493 760 for a total coverage angle of 2π . The grid quality check was performed using the Turbo Grid application.

Boundary conditions in the ANSYS CFX 12.0 software: the total pressure (P^* , Pa) and stagnation temperature (T^* , K) were set at the entrance to the computational domain, and the mass flow rate (\dot{m} , kg / s) at the exit from the computational domain.

A zero value of the velocity $u = 0$ is taken on the walls of the vaneless diffuser and on the Impeller contour. The wall surfaces are assumed to be hydraulically smooth.

The inverse Euler method of the second order in time was used when discretizing the unsteady scheme. A high-resolution sampling scheme was used for transfer and turbulence. The value of the convergence control of the loop coefficient was chosen less than 5. Calculations were performed using supercomputer (cluster) technologies over the entire coverage angle 2π for the entire flow path. Turbulence models were used: a) shear stress transfer (SST); b) large eddies (LES); c) k- ϵ RNG; d) SAS SST. The convergence criterion 10^{-6} is set. Establishment of the accepted criterion of convergence occurred with successive calculations above the 5th rotor revolution (up to the 20th rotor revolution). The need for calculations for sequential revolutions was determined by the features of the "transient rotor - stator" interface. The level of turbulence intensity is assumed to be 1%. While calculating the duration of the numerical solution T and ΔT - the time step was set. The final state of the simulation time was determined from the condition $N \cdot \Delta T \geq T$, where N is the time step number.

The key point of using computing systems is verification and validation of results. Comparison of the calculated and experimental data is carried out for pneumometric results (characteristics of the impeller and the stage with full and static parameters, as well as the distribution fields of total pressures along the width and radius of the vaneless diffuser) [12-14, 20-24]. The comparison results show an acceptable qualitative and quantitative agreement between calculations and experiments with an ambiguity of no more than 5%.

The results of calculating unsteady processes are clearly divided into two groups. A periodic process of propagation of swirls in a vaneless diffuser plays the main role in the area of flow rates from maximum to the occurrence of a rotating breakaway.

The picture of the propagation of static and total pressure pulsations in a vaneless diffuser is shown in fig. 5 and 6. The periodic character of the pulsations remains until the exit from the diffuser, while the influence of the three-dimensionality of the flow on the intensity of the total pressure pulsations (Fig. 6) at the initial section of the diffuser is noticeable.

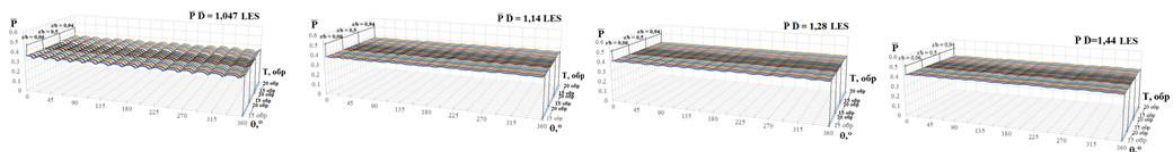

Fig. 5. Fluctuation P^- in the vaneless diffuser, ($z/b = 0.06; 0.5; 0.94$), $\varphi_0 = \varphi_{opt}$.

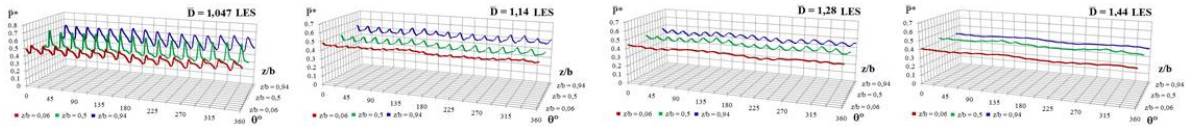
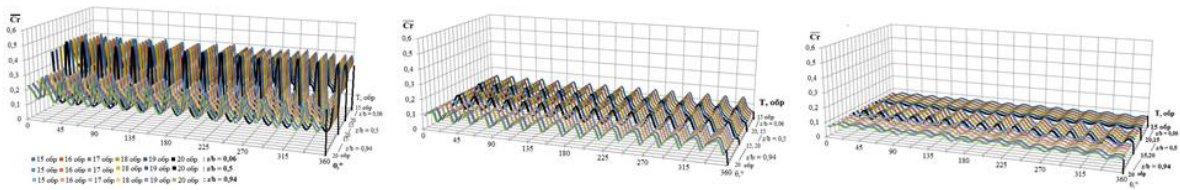
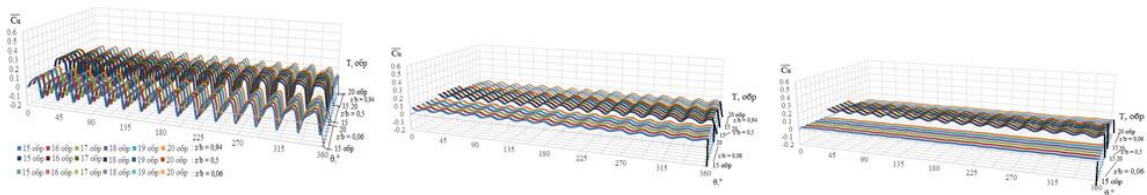

Fig. 6. Fluctuation P^* in vaneless diffuser, ($z/b = 0.06; 0.5; 0.94$), $\varphi_0 = \varphi_{opt}$.

The pattern of the radial pulsations propagation (Fig. 7) and circumferential (Fig. 8) components of the velocities is generally similar; it should be noted that the pulsations $\overline{C\bar{u}}$ at the diffuser walls decay due to friction. The qualitative and quantitative coincidence of the calculations results and experiments [12, 13] shows that the ANSYS CFX 12 (URANS) platform can be used to calculate unsteady flows using the LES, SST and RNG turbulence models (the SAS SST model showed unacceptable results both in stable operation modes and with rotating breakaway).



a) b) c)
Fig. 7. Fluctuation $\overline{C\bar{u}}$ in vaneless diffuser, ($z/b = 0.06; 0.5; 0.94$), $\varphi_0 = \varphi_{0opt}$, D/D_2 : a) 1,047; b) 1,28; c) 1,44



a) b) c)
Fig. 8. Fluctuation $\overline{C\bar{u}}$ in vaneless diffuser, ($z/b = 0.06; 0.5; 0.94$), $\varphi_0 = \varphi_{0opt}$, D/D_2 : a) 1,047; b) 1,28; c) 1,44

Conclusions

The use of the developed virtual stand for the study of unsteady processes in the compressor flow path makes it possible to detect the occurrence of a rotating breakaway (the so-called pre- breakaway) in the region $\varphi_{0opt} < \varphi_0 \leq \varphi_{0break}$, corresponding to the experimental data. However, if the parameters of the rotating breakaway in the impeller correspond in order of magnitude to the experimental data, the calculated pulsation frequency in the vaneless diffuser differs significantly from those observed in the experiment. This is due to the aspect of calculations using the "transient rotor - stator" interface, which transfers data from a rotating rotor to a fixed vaneless diffuser. Since, during rotating breakaway, the separation zones move along a circle with a low angular velocity ($\omega_z \ll \omega_{rot}$), the rotation frequency synchronization performed by the interface leads to a discrepancy between the numerical estimates of the rotating stall observed in the experiment. An important

point in the design is to determine the strength characteristics of the main loaded structural elements. It is necessary that these elements meet the strength conditions.

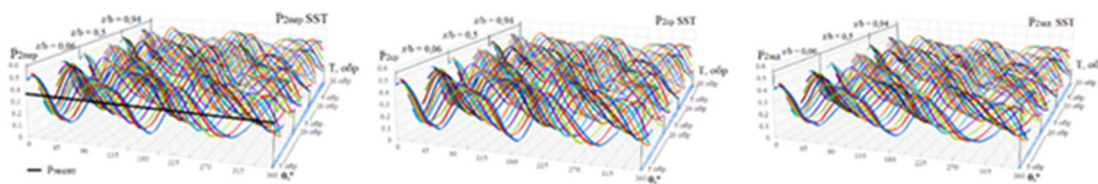

Fig.9. Fluctuation P_2 at the periphery of the Impeller, $\varphi_0 = \varphi_{0break}$.

An illustration of the capabilities of a virtual stand for studying unsteady processes in the flow path of a centrifugal compressor is shown in Fig. 10 and 11 [14]. The presented picture of streamlines (Fig. 10) shows that a rotating breakaway occurs due to the separation of the radial velocity component in a bladeless diffuser, which confirms the breakaway model proposed by V. Jansen [25-27]. Obtaining such distributions in an experiment requires a huge investment of time.

References

1. Izmaylov R. A. (1987), Unsteady aerodynamic processes in centrifugal compressors. Dis. Dr. tech. sciences., Kalinin LPI, pp. 527
2. Yuan Liu, Manuj Dhingra, J. V. R. Prasad Active Compressor Stability Management Via a Stall Margin Control Mode J. Eng. Gas Turbines Power. May 2010, 132(5): 051602 (10 pages) <https://doi.org/10.1115/1.3204652>
3. U. Haupt, K. Bammert, M. Rautenberg Blade Vibration on Centrifugal Compressors: Blade Response to Different Excitation Conditions Paper No: 85-GT-93, V004T13A007; 10 pages <https://doi.org/10.1115/85-GT-93>
4. R. P. J. O. M. van Rooij, J. G. Schepers The Effect of Blade Geometry on Blade Stall Characteristics J. Sol. Energy Eng. Nov 2005, 127(4): 496-502 (7 pages) <https://doi.org/10.1115/1.2037090>
5. D. Dane Quinn Resonant Dynamics in a Rotordynamic System With Nonlinear Inertial Coupling and Shaft Anisotropy Paper No: IMECE2005-81946, pp. 225-232; 8 pages <https://doi.org/10.1115/IMECE2005-81946>
6. Anil Prasad Evolution of Upstream Propagating Shock Waves From a Transonic Compressor Rotor J. Turbomach. Jan 2003, 125(1): 133-140 (8 pages) <https://doi.org/10.1115/1.1516813>
7. D. Christensen, P. Cantin, D. Gutz, P. N. Szucs, A. R. Wadia, J. Armor, M. Dhingra, Y. Neumeier, J. V. R. Prasad Development and Demonstration of a Stability

Management System for Gas Turbine Engines J. Turbomach. Jul 2008, 130(3): 031011 (9 pages) <https://doi.org/10.1115/1.2777176>

8. Anil Prasad Evolution of Upstream Propagating Shock Waves From a Transonic Compressor Rotor Paper No: GT2002-30356, pp. 299-309; 11 pages <https://doi.org/10.1115/GT2002-30356>

9. Yuan Liu, Manuj Dhingra, J. V. R. Prasad Correlation Measure-Based Stall Margin Estimation for a Single-Stage Axial Compressor J. Eng. Gas Turbines Power. Jan 2012, 134(1): 011603 (9 pages) <https://doi.org/10.1115/1.4004177>

10. Nicolas Gourdain, Francis Leboeuf Unsteady Simulation of an Axial Compressor Stage With Casing and Blade Passive Treatments J. Turbomach. Apr 2009, 131(2): 021013 (12 pages) <https://doi.org/10.1115/1.2988156>

11. Kononov S.V. (1985), The structure of unsteady flow in the steps of a centrifugal compressor with a bladeless diffuser and the choice of informative parameters for the diagnosis of unstable operation. Dis. Cand. tech. sciences., Kalinin LPI, pp. 156

12. Izmaylov R.A., Lopulalan Kh. D., Norimarna G. S. (2011), Numerical modeling of unsteady flow in the centrifugal compressor stage. / Compressor technology and pneumatics, No. 5, pp. 10-15

13. Izmaylov R.A., Lopulalan Kh. D., Norimarna G. S. (2011), Virtual stand for the study of unsteady processes in the centrifugal compressor stage. / Compressor technology and pneumatics, No. 6, pp. 11-16

14. Lopulalan Kh. D. (2014), Virtual stand for the study of non-stationary processes in the steps of a centrifugal compressor. Dis. Cand. tech. sciences. SPb. SPbPU, pp. 156

15. ANSYS Inc. (2009), ANSYS CFX Release 12.0. User Manual

16. David J. Laino, A. Craig Hansen, Jeff E. Minnema Validation of the AeroDyn Subroutines Using NREL Unsteady Aerodynamics Experiment Data Paper No: WIND2002-39, pp. 179-189; 11 pages <https://doi.org/10.1115/WIND2002-39>

17. Parthasarathy Vasanthakumar Computation of Aerodynamic Damping for Flutter Analysis of a Transonic Fan Paper No: GT2011-46597, pp. 1429-1437; 9 pages <https://doi.org/10.1115/GT2011-46597>

18. Baizura Bohari, Abdulnaser Sayma CFD Analysis of Effects of Damage Due to Bird Strike on Fan Performance Paper No: GT2010-22365, pp. 173-181; 9 pages <https://doi.org/10.1115/GT2010-22365>

19. Mohammad Javad Shahriyari, Hossein Khaleghi, Martin Heinrich Model for Stall and Surge in Low-Speed Contra-Rotating Fans J. Eng. Gas Turbines Power. Aug 2019, 141(8): 081009 (11 pages) Paper No: GTP-18-1693 <https://doi.org/10.1115/1.4043251>

20. Boldyrev, Y., Rubtsov, A., Kozhukhov, Y., Lebedev, A., Cheglakov, I., Danilishin, A. Simulation of unsteady processes in turbomachines based on nonlinear harmonic NLH-method with the use of supercomputers. CEUR Workshop Proceedings. Volume 1482, 2015, Pages 273-279. 1st Russian Conference on Supercomputing Days 2015, RuSCDays 2015; Moscow; Russian Federation; 28 September 2015 до 29 September 2015.

MORE ABOUT COMPRESSOR TECHNOLOGY AT WWW.KVIHT.COM
БОЛЬШЕ О КОМПРЕССОРНОЙ ТЕХНИКЕ НА WWW.KVIHT.RU

21. Danilishin, A.M., Kozhukhov, Y.V., Kartashov, S.V., Lebedev, A.A., Malev, K.G., Mironov, Y.R. Design optimization opportunity of the end stage output plenum chamber of the centrifugal compressor for gas pumping unit. (2018) AIP Conference Proceedings, 2007, № 30044. DOI: 10.1063/1.5051905

22. Neverov, V.V., Kozhukhov, Y.V., Yablokov, A.M., Lebedev, A.A. The experience in application of methods of computational fluid dynamics in correction of the designed flow path of a two-stage compressor. (2018) AIP Conference Proceedings, 2007, № 30048. DOI: 10.1063/1.5051909

23. Aksenov, A.A., Danilishin, A.M., Dubenko, A.M., Kozhukhov, Y.V. Development of the virtual experimental bench on the basis of modernized research centrifugal compressor stage test unit with the 3D impeller. IOP Conference Series: Materials Science and Engineering, 2017, 232(1), 012042. 10th International Conference on Compressors and Their Systems; City, University of London; United Kingdom; 11 September 2017 with 13 September 2017. DOI: 10.1088/1757-899X/232/1/012042

24. Aksenov, A.A., Danilishin, A.M., Kozhukhov, Y.V., Simonov, A.M. Numerical simulation of gas-dynamic characteristics of the semi-open 3D impellers of the two-element centrifugal compressors stages (2018) AIP Conference Proceedings, 2007, № 030025. DOI:10.1063/1.5051886

25. Jansen W. (1960), Quasi-unsteady flow in a radial vaneless diffuser. Massachusetts Institute of Technology // Gas Turbine lab. Report No. 60, pp. 105

26. Wei Han, Hongguang Jin A New Kind of Multifunctional Energy System Based on Moderate Conversion of Chemical Energy of Fossil Fuels J. Eng. Gas Turbines Power. May 2010, 132(5): 051401. doi: <https://doi.org/10.1115/1.3205025>

27. J. Gannon, G. V. Hobson, R. P. Shreeve, I. J. Villescas Experimental Investigation During Stall and Surge in a Transonic Fan Stage and Rotor-Only Configuration Paper No: GT2006-90925, pp. 367-376; 10 pages <https://doi.org/10.1115/GT2006-90925>

MORE ABOUT COMPRESSOR TECHNOLOGY AT WWW.KVIHT.COM
БОЛЬШЕ О КОМПРЕССОРНОЙ ТЕХНИКЕ НА WWW.KVIHT.RU